



Real World Deployment of Mobile Material Handling Robotics in the Supply Chain

Peter Santos

Chief Operating Officer

Pickle Robot Company

Real World Deployment of Mobile Material Handling Robots

Complexity
Acceptance

Test/Validation
Strategy

Customer
Collaboration

Next generation Material Handling Automation is here

1st Generation: Electro-Mechanical



2nd Generation: Structured

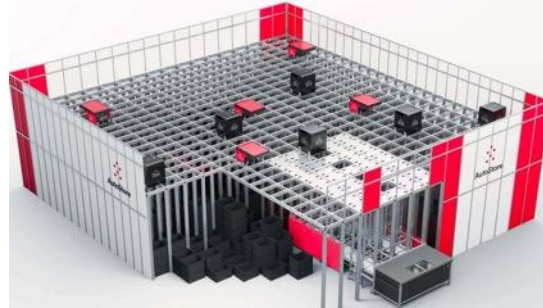

Next Generation: Un-Structured (requires AI)



Complexity Acceptance

Un-Structured Material Handling involves massive freight complexity

- Size distribution
- Weight distribution
- Structure
- Carton graphics
- Cardboard quality
- Non-carton packages/parcels



Validation & test of un-structured handling systems is hard

These systems are AI-based; AIs are not designed systems of functions

- Cannot test against functional theory of operation
- Must test against representation of actual operating conditions

Functional control system

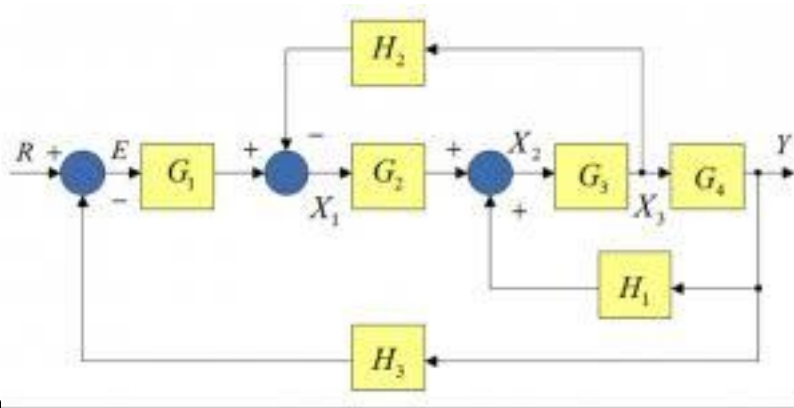

AI control system

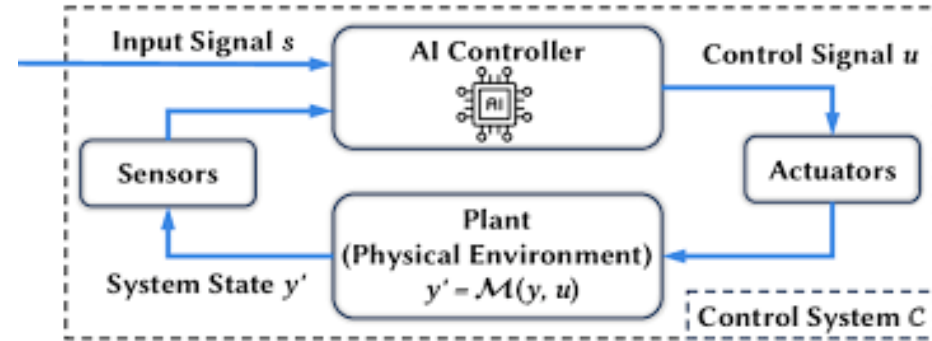

Mobile material handling adds complexity

- Mobile autonomous equipment must deal with complexity of space
 - They exist in the field today
- Stationary material handlers deal with complexity of freight
 - They exist in the field today
- Mobile material handlers must operate within the complexity of **both** space and freight, simultaneously
 - They are just now entering the field



Test and validation strategy

Mapping test to design: the V Model

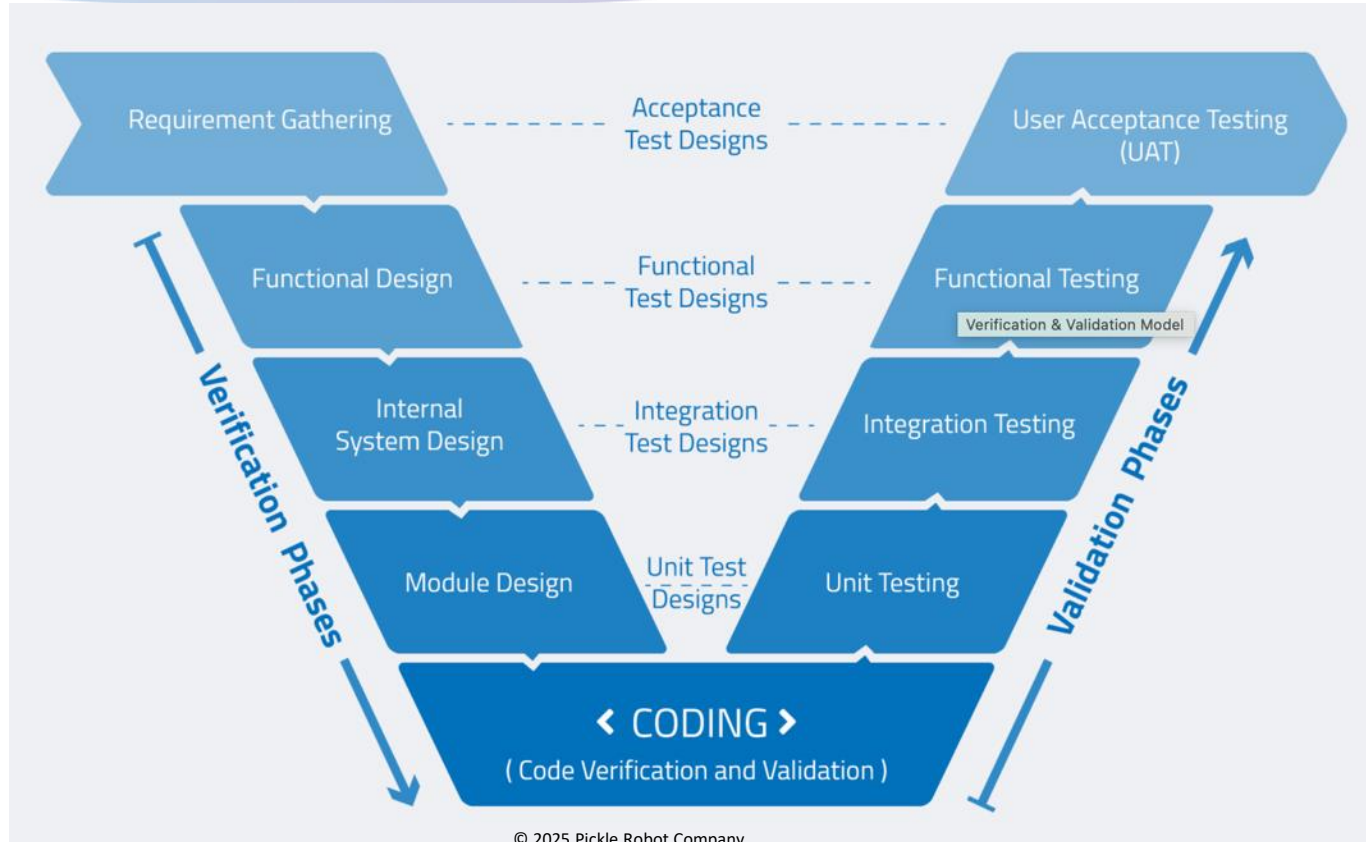

A staged approach to System Test is necessary

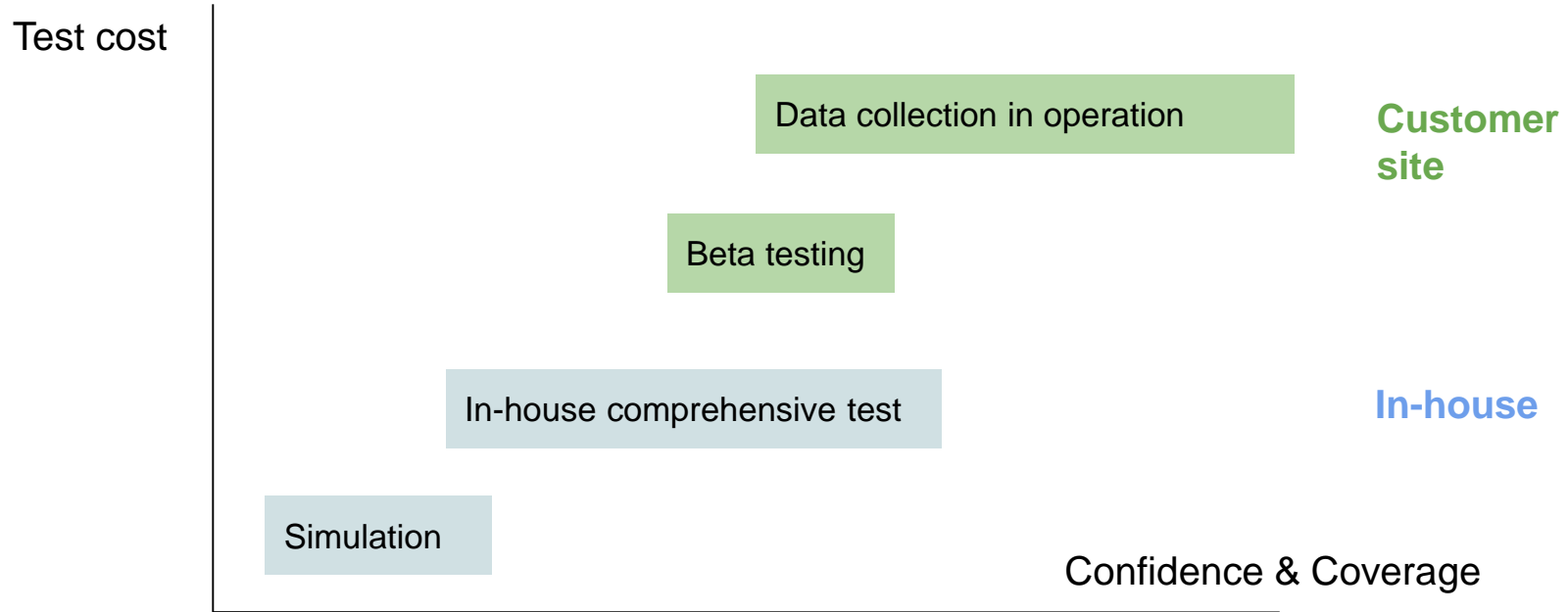

The stages have different key attributes

Internal design validation

Customer site test & validation

Simulation

In-House Testing

Beta testing

Production data
collection

Material Handling Burden	Zero	Very High	Low	Zero
Test coverage	Very high	Moderate	High	Very High
Coverage control	High	High	Low	Moderate
Accuracy	Low	Moderate	High	Very High
Suitable for Validation	Yes	Yes	Somewhat	No
Key Requirements	Excellent simulation system	High volume test operation	Customer collaboration	Fleet management system

Customer relationships

When a real test is only possible in the field, customers are key participants in your test & validation process

- Beta testing
 - Must run in a production setting that is forgiving of variable performance
 - Beta performance must suffice to not completely shut down material flow
 - Customer must
 - Perceive long-term, meaningful benefit in larger deployment
 - Trust the vendor
- Data collection in operation
 - The trade with the customer is data for improved performance
 - Part of the “data” is results from a much larger test set that used previously

These steps are critical for AI-based robot development

Laying the foundation for the test plan begins in Sales

- Prospecting & closing must select for at least some customers who can be long-term beta testers
- This aspect must become part of the sales process for such customers
- Sales personnel must be trained and skilled in making this part of their account management strategy

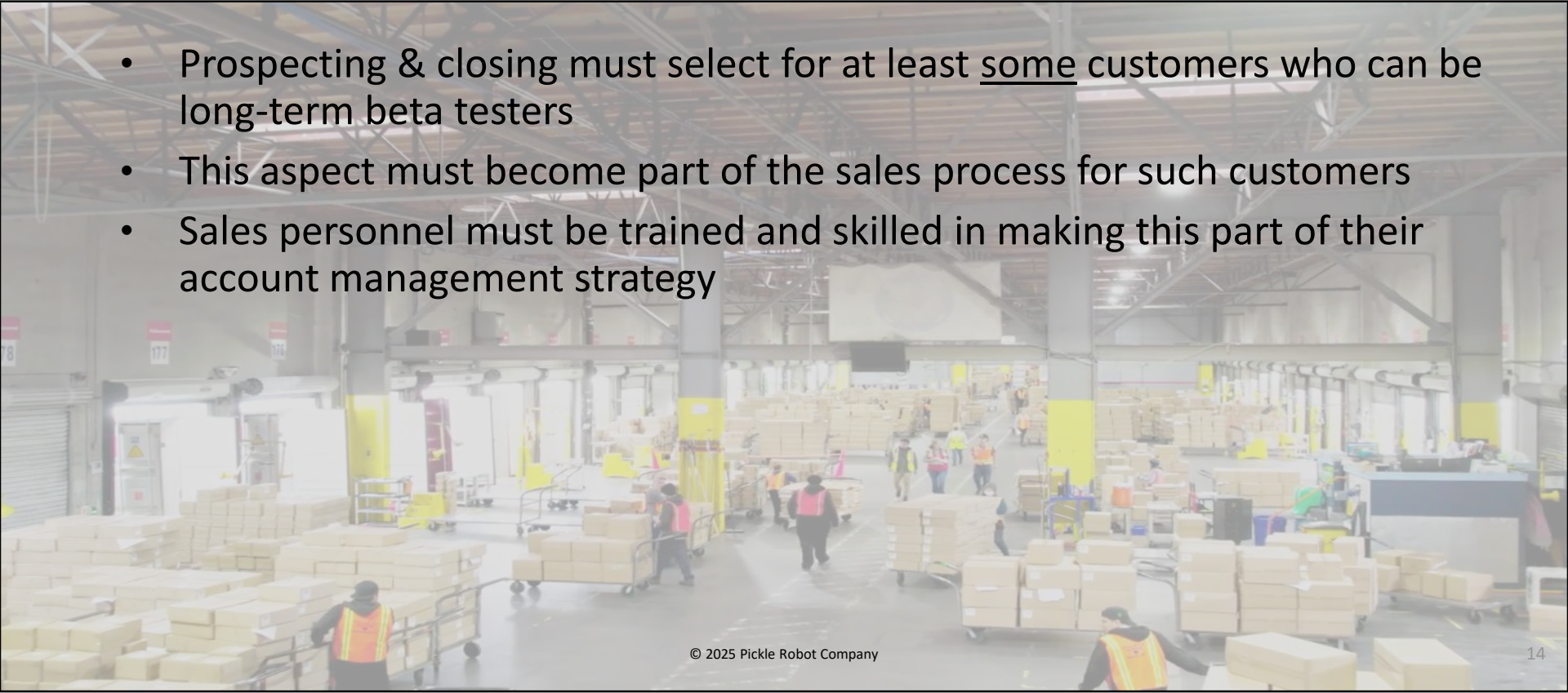

Complexity Acceptance

Real freight is messy,
real validation must
address it

Test/Validation Strategy

Balance cost, accuracy
& time across product
life cycle

Customer Collaboration

Close development
partnerships with
customers with right
freight flow is key

"We are thrilled about this partnership with Pickle Robot Company. It aligns with our commitment to innovation, improving our employees' work environment, and delivering exceptional service to our customers."

- John Rae, VP of Operations, Yusen Contract Logistics

- Pickle Robot Company
 - <https://picklerobot.com/>
- Verification/Validation model
 - <https://www.technolush.com/blog/verification-validation-model>
- Drake Robotics Verification
 - <https://drake.mit.edu/>